

1575 Gate EMLock[®] Solution

Outside

Inside

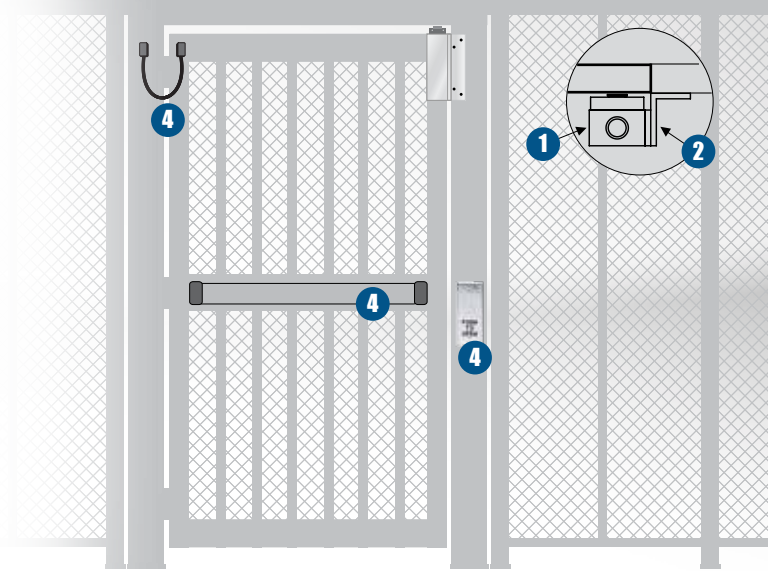

1 Gate Magnetic Lock



1575U

- Stainless Steel Case
- Epoxy filled for weather resistance
- Threaded conduit fitting
- Built-in voltage kickback protection
- Low power consumption
- Built-in bond sensor (BAS)
- Built-in door sensor (DPS)

2 Gate Mount Brackets

1575-BK

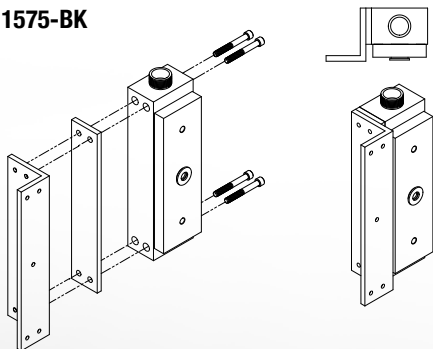

3 Outdoor Access Control (Pick one)



4 Request-To-Exit (Pick one)



5 Power Supply

12 or 24 VDC Output



OPTIONAL BATTERY BACKUP
RB12V4-2



The lock behind your system

(800) 413-8783 ■ WWW.SDCSECURITY.COM