

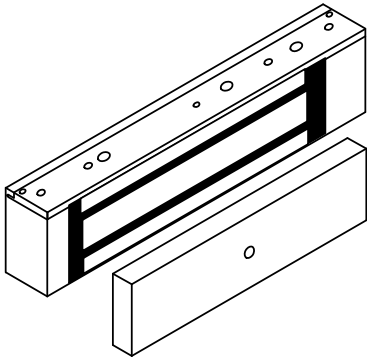

801 Avenida Acaso, Camarillo, Ca. 93012 • (805) 494-0622 •  
www.sdcsecurity.com • E-mail: service@sdsecurity.com

### INSTALLATION INSTRUCTIONS E300 SERIES MAGNETIC CABINET/DISPLAY CASE LOCK

The E300 Series magnetic lock is mounted to the underside of the cabinet housing or vertically inside the cabinet.



#### Electrical Specifications:

Dual Voltage 12 or 24VDC

Power Consumption 360mA@12VDC  
180mA@24VDC

LS Lock Status Sensor SPDT, 250mA@30VDC



Select jumper position for 12VDC or 24VDC.  
Connect power to magnetic lock.

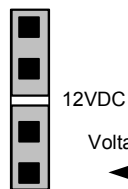
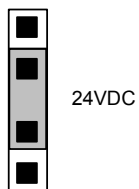

Voltage Jumper

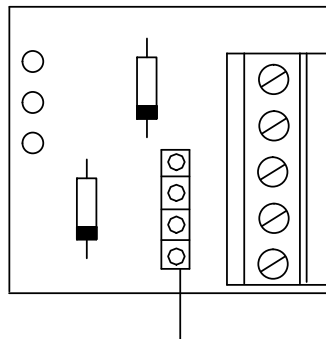

+ → Power  
- → Supply

N/O CLOSED WITH POWER & DOOR CLOSED

COM

N/C OPEN WITH POWER & DOOR CLOSED

Lock Status Switch

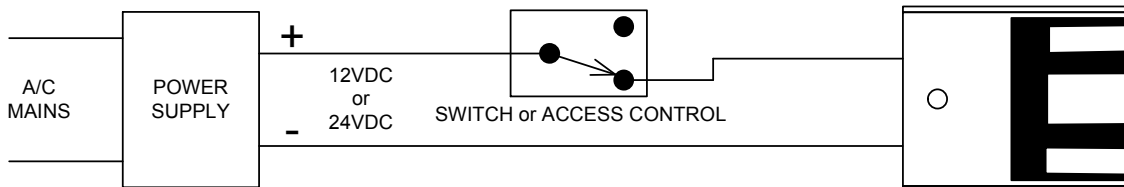

Test operation. After verifying proper operation, tighten all screws as shown. Install anti-tamper plugs over socket screws using a soft hammer to avoid damage to the housing.

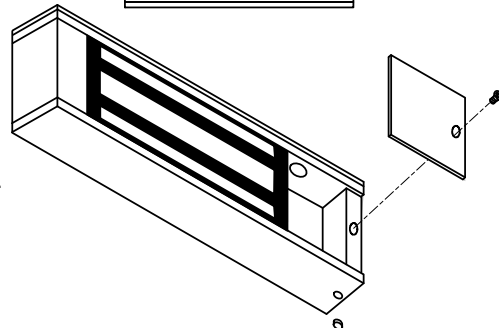

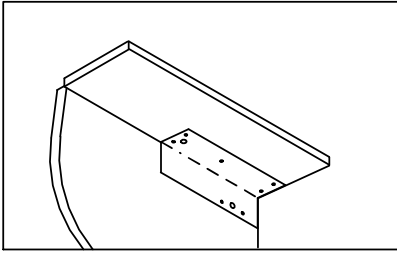

**STEP 1**

- FOLD TEMPLATE ALONG DOTTED LINE.

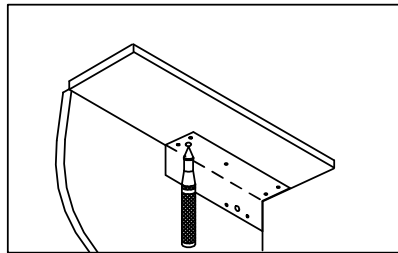

- PLACE TEMPLATE AGAINST CABINET DOOR AND FRAME.

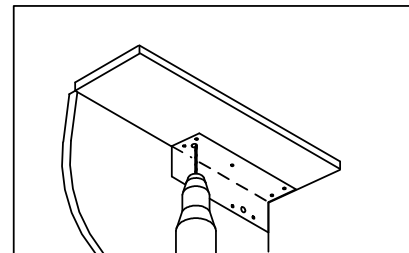

- DRILL HOLES AS INDICATED ON TEMPLATE.

**STEP 2**

- MOUNT THE ARMATURE PLATE TO DOOR USING (1) RUBBER WASHER SANDWICHED BETWEEN (2) STEEL WASHERS (THE RUBBER WASHER AND (2) STEEL WASHERS ARE INSTALLED ON THE MOUNTING BOLT BETWEEN THE ARMATURE PLATE AND DOOR).

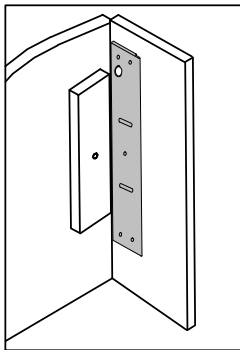
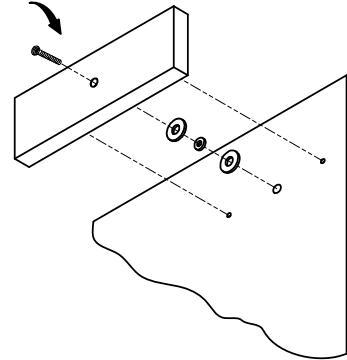

**STEP 3**

- INSTALL THE MOUNTING PLATE
- ADJUST THE MOUNTING PLATE SO THAT IT AND THE ARMATURE FORM A RIGHT ANGLE.
- INSTALL THE REMAINING MOUNTING SCREWS.

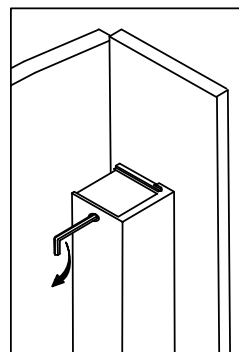
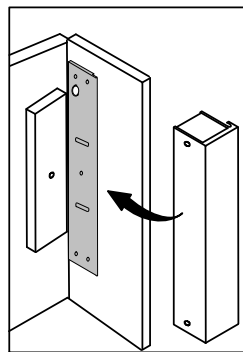

**STEP 4**

- INSTALL MAGNET TO MOUNTING PLATE.

**CAUTION:** The lock body must be held in place until secured with mounting screws. Secure socket head screws provided inside the housing at each end. Start screws into threads carefully to avoid stripping the threads. Check alignment and tighten screws. Pull wires through frame, mounting plate and magnet housing