

SDC Security Door Controls

801 Avenida Acaso, Camarillo, Ca. 93012 • (805) 494-0622 •
www.sdcsecurity.com • E-mail: service@sdsecurity.com

INSTALLATION INSTRUCTIONS ELECTRIC LATCH RETRACTION KIT LR100FAK FALCON(Dor-O-Matic) MODELS: 1690 & 1790

Remove Push Bar. Remove Dogging Assembly. Slide the ELR unit into the device base. Align the first set of two holes over the two base unit holes and attach with the two #10-32 flat head screws supplied. Attach the Linkage to the device as shown. Re-attach the Push Bar.

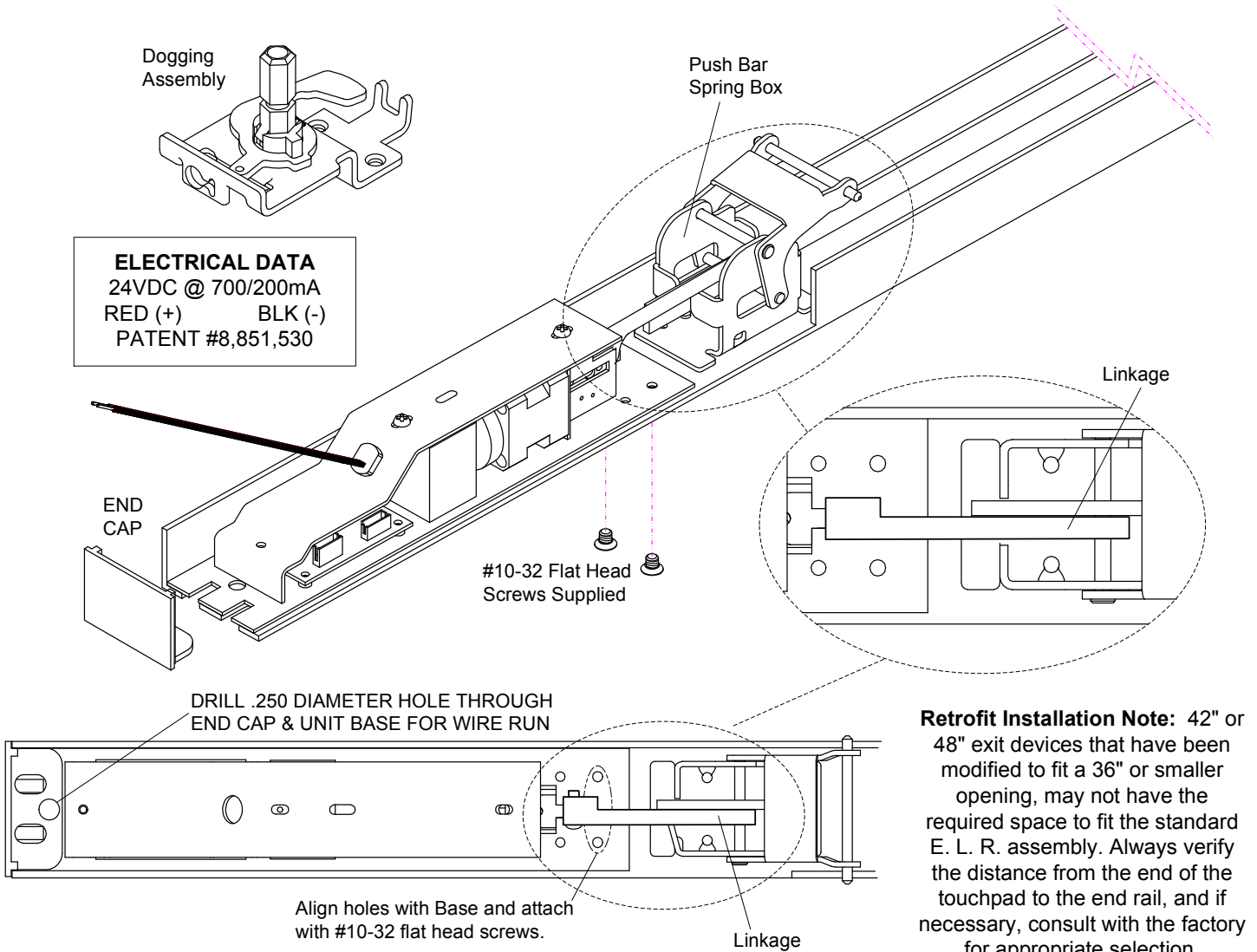

When retrofitting to existing vertical rod devices, adjustment of the rods is required for proper operation of the Electric Latch Retractor. Once the unit is properly installed, energize it so the push pad is dogged down, then reconnect the vertical rods to the device and make the proper adjustments.

Any suggestions or comments to this instruction or product are welcome. Please contact us through our website or email engineer@sdsecurity.com