

SDC Security Door Controls

801 Avenida Acaso, Camarillo, Ca. 93012 • (805) 494-0622 •
 www.sdcsecurity.com • E-mail: service@sdsecurity.com

INSTALLATION INSTRUCTIONS LR100FCK-EM ELECTRIC LATCH RETRACTION KIT EXTERNAL MODULE FIRST CHOICE MODELS: 3600 & 3700

Remove Push Bar. Remove Dogging Assembly. Slide the ELR unit into the device base. Align the first set of two holes over the two base unit holes and attach with the two #10-32 flat head screws supplied. Attach the Linkage to the device as shown. Re-attach the Push Bar.

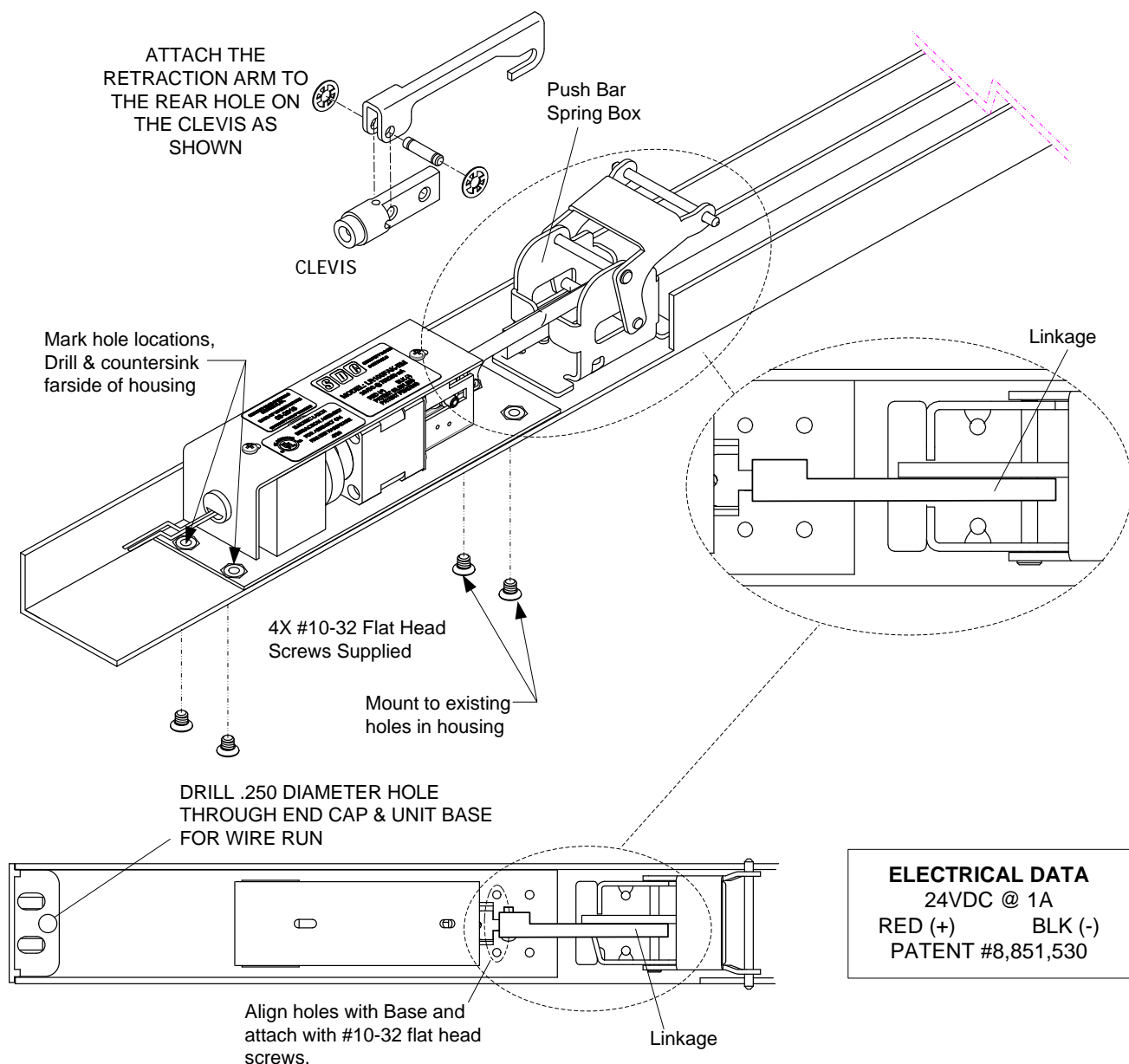

| | |
|------------------------|---------|
| ELECTRICAL DATA | |
| 24VDC @ 1A | |
| RED (+) | BLK (-) |
| PATENT #8,851,530 | |

Any suggestions or comments to this instruction or product are welcome. Please contact us through our website or email engineer@sdsecurity.com

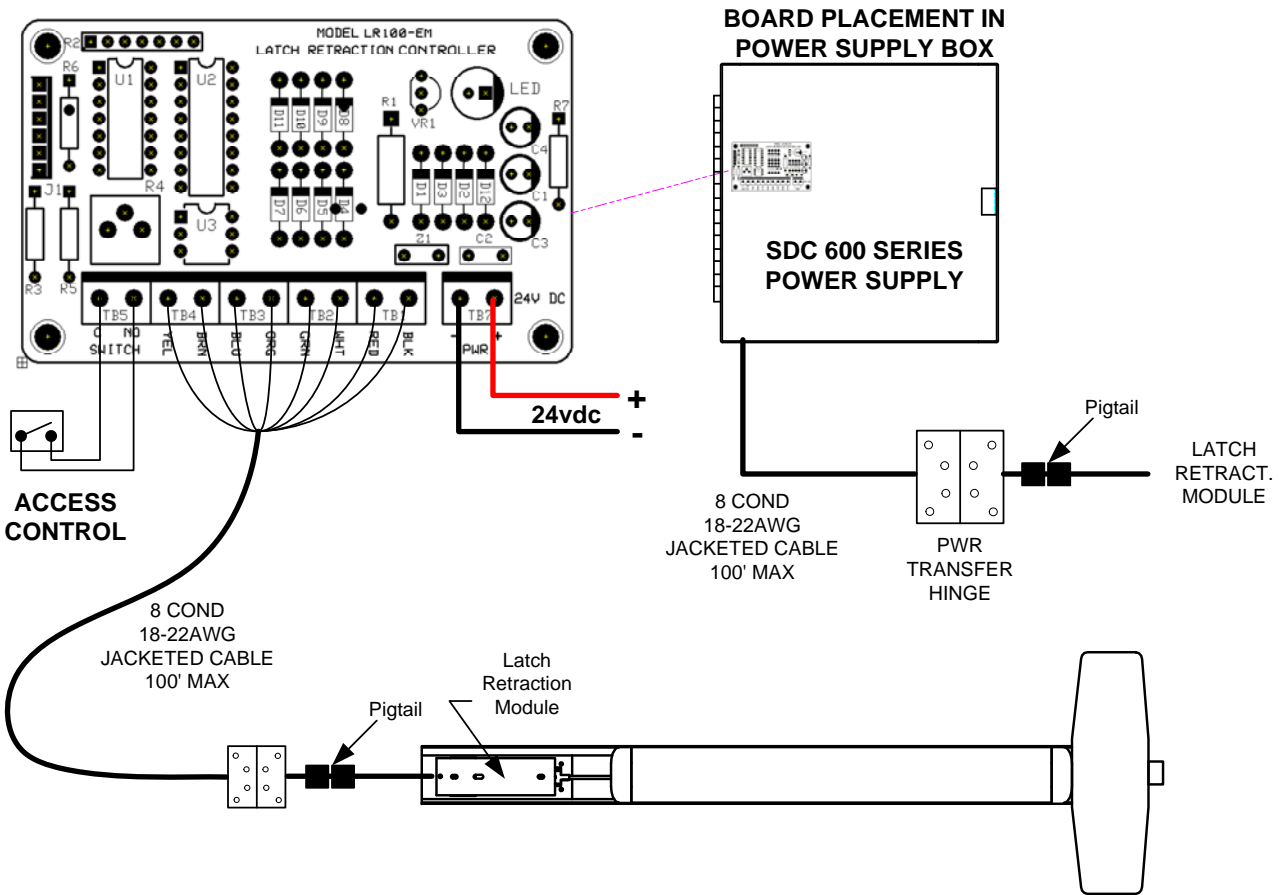

Retrofit Installation Note: 42" or 48" exit devices that have been modified to fit a 36" or smaller opening, may not have the required space to fit the standard E. L. R. assembly. Always verify the distance from the end of the touchpad to the end rail, and if necessary, consult with the factory for appropriate selection.

NOTE Retro-Fitting Vertical Rod Devices:

Before retro-fitting an electric latch assembly into a vertical device, the following must be done to ensure proper alignment. Disconnect the vertical rods from the device. Install the electric latch assembly as shown above. Once the ELR is properly installed energize it so that the push pad is dogged down, by doing so it will allow for proper alignment for the vertical rods. Finally reconnect the vertical rods to the device and make the proper adjustments.