



# INSTALLATION INSTRUCTIONS

## LRVD1R VON DUPRIN REQUEST-TO-EXIT SWITCH KIT MODELS: 98/99 & 33/35 SERIES

Insert switch assembly into the extrusion with the back of the angle bracket against the inside wall of the extrusion.

Slide the switch assembly toward the device head until it's on top of the push pad baseplate.

Adjust the switch assembly accordingly within the device until the snap action switch makes proper contact with the tailpiece of the exit device, then tighten the set screw to secure in place.

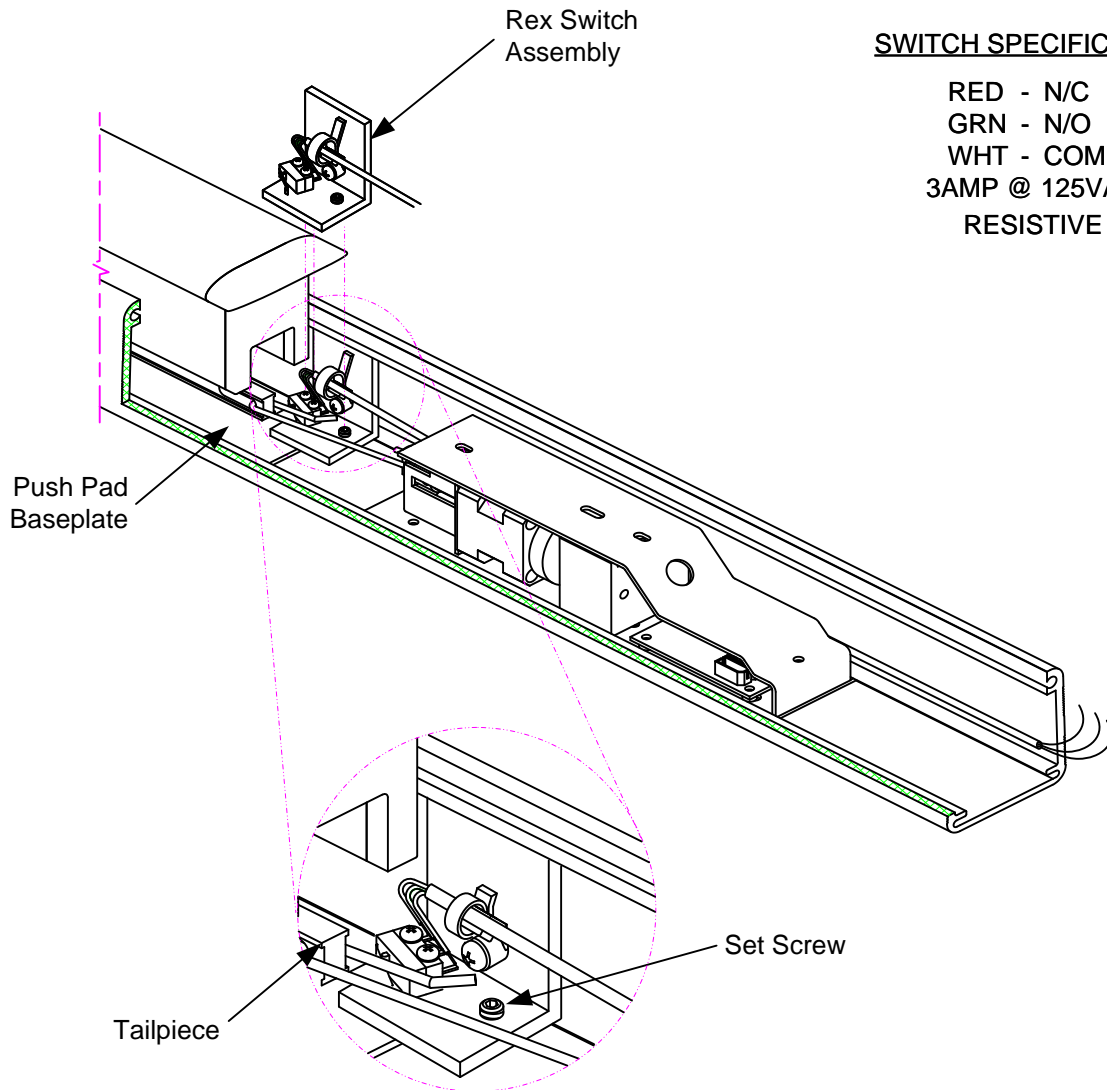

### SWITCH SPECIFICATION

RED - N/C  
GRN - N/O  
WHT - COM  
3AMP @ 125VAC  
RESISTIVE