

SDC Security Door Controls

801 Avenida Acaso, Camarillo, Ca. 93012 • (805) 494-0622 •
www.sdcsecurity.com • E-mail: service@sdsecurity.com

TEMPLATE 2090AWD WOOD DOOR & FRAME APPLICATION

NOTE: TEMPLATE DIMENSIONS ARE
SUBJECT TO CHANGE WITHOUT NOTICE.

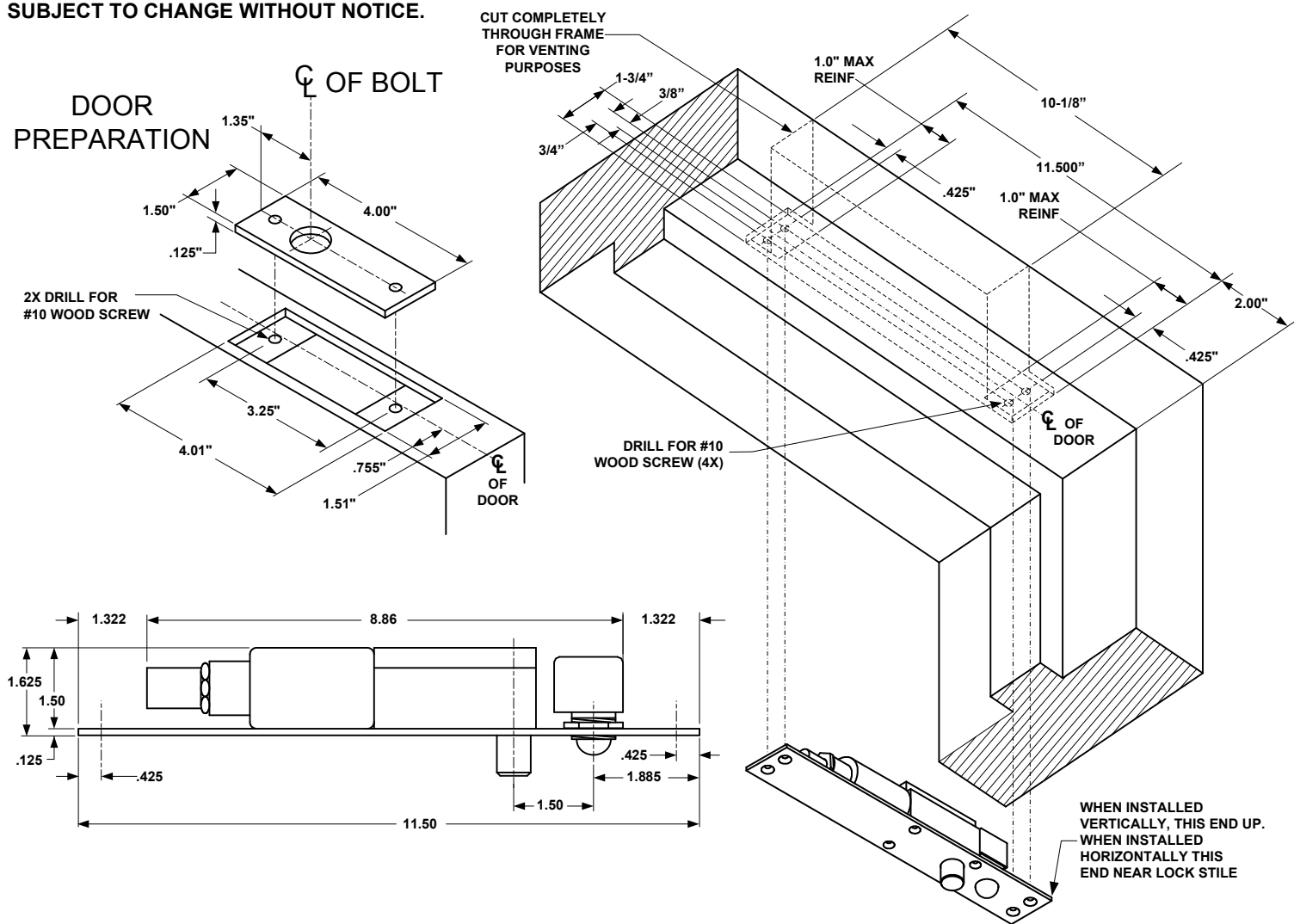

TECHNICAL DATA

FACE PLATE: 11-1/2" x 1-3/4" x 1/8"
STRIKE: 4" x 1-1/2" x 1/8"
ID REQUIREMENTS: 10" x 1-1/2" x 1-1/2"
FINISH: 630 STAINLESS STEEL (PLATED FINISHES OPTIONAL)
BOLT: 3/4" DIA. SOLID STAINLESS STEEL
BOLT THROW: 3/4", ROTATING
FAIL-SECURE – UNLOCKED WHEN ENERGIZED
AUTO RELOCK SWITCH: ADJUSTABLE BALL TYPE
SOLENOID: CONTINUOUS DUTY
ELECTRICAL DATA:
 INRUSH 60 WATTS – 2.5 AMPS MAX.
 SEATED 8 WATTS - .32 AMP MAX. @ 24VDC
 (SPECIFY VOLTAGE REQUIRED)
STATUS SENSORS: BOLT AND DOOR POSITION (OPTIONAL)

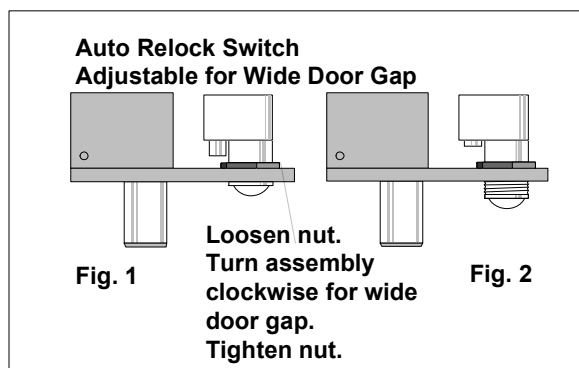

Any suggestions or comments to this instruction or product are welcome. Please contact us through our website or email engineer@sdsecurity.com