

System Components:

- (1) **602RFXUR-1** – 1 Amp Regulated Power Supply w/ Fire Alarm Interface & Universal Relay Module
- (1) **1512VD** – 1650lb Grade 1 Double-door EMLock®
- (1) **431OUL1R** – Green 1.5" Mushroom Button, Alternate-action, SPST (NO), w/ integral Red LED
- (1) **702NU** – 6A Key Switch, Narrow, Momentary, SPDT
- (1) **CYL-KDQ** – 1-1/8" Key cylinder with 2 keys, for 700 Series Key Switch

Model 602RFXUR-1

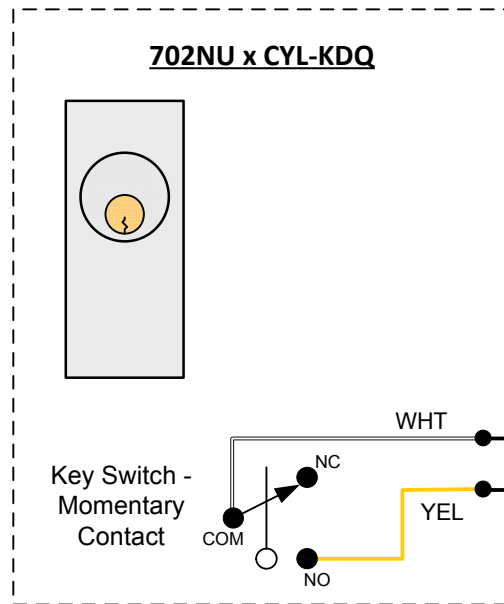
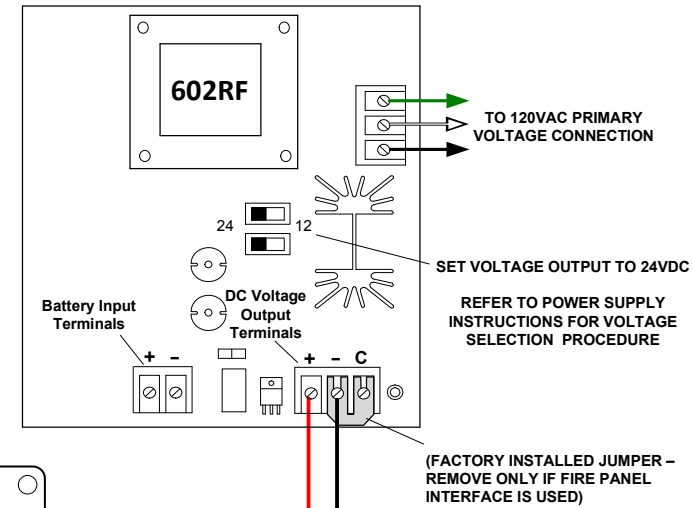

Set Dip Switch #3 On
All other switches Off

Time Adj
(1-60 sec.)

Relay Output Jumpers
Set to D = Dry

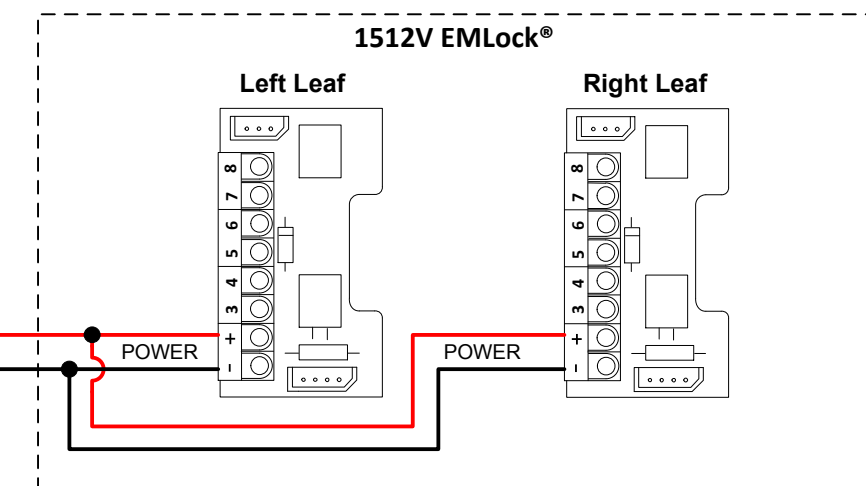
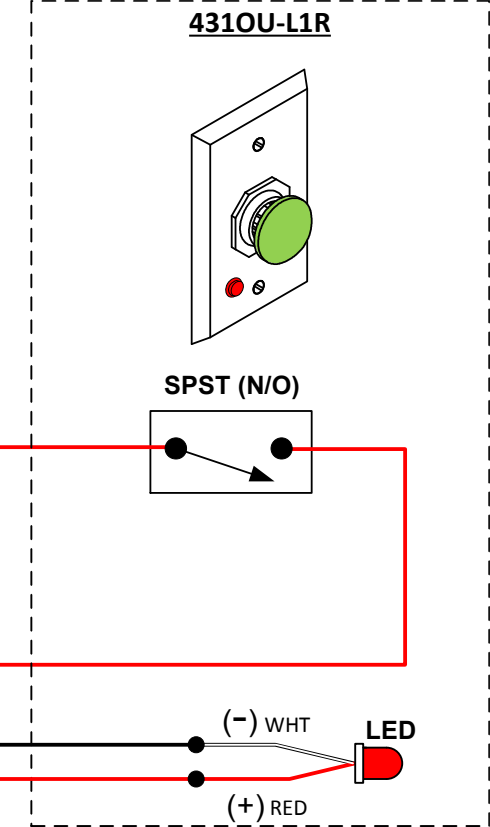
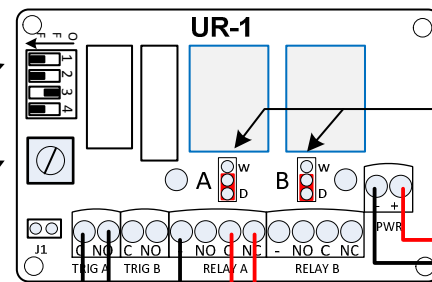

METHOD OF OPERATION / APPLICATION USE:

For general convenience store / gas station front double entry doors. Maglock to be in de-energized state (open) until store clerk activates the latching mushroom switch to lock the front double entry doors. Once the threat is all clear, then the store clerk will reactivate the mushroom switch to de-activate the maglock, unlocking the front entry doors.

An integral Red LED will indicate the status of the maglock (LED ON = Power Applied; LED OFF = Power removed). The key switch is for general momentary override in an emergency situation. The override unlock time is adjusted through the UR1 timer.

A signal from the Fire Alarm Panel will automatically release the magnetic lock, allowing free egress.

