

SDC Security Door Controls

801 Avenida Acaso, Camarillo, Ca. 93012 • (805) 494-0622 •
www.sdcsecurity.com • E-mail: service@sdsecurity.com

INSTALLATION INSTRUCTIONS IP100CRK CORBIN/RUSSWIN ELECTRIC LATCH RETRACTION DEVICE KIT MODELS: ED4200 & ED5200

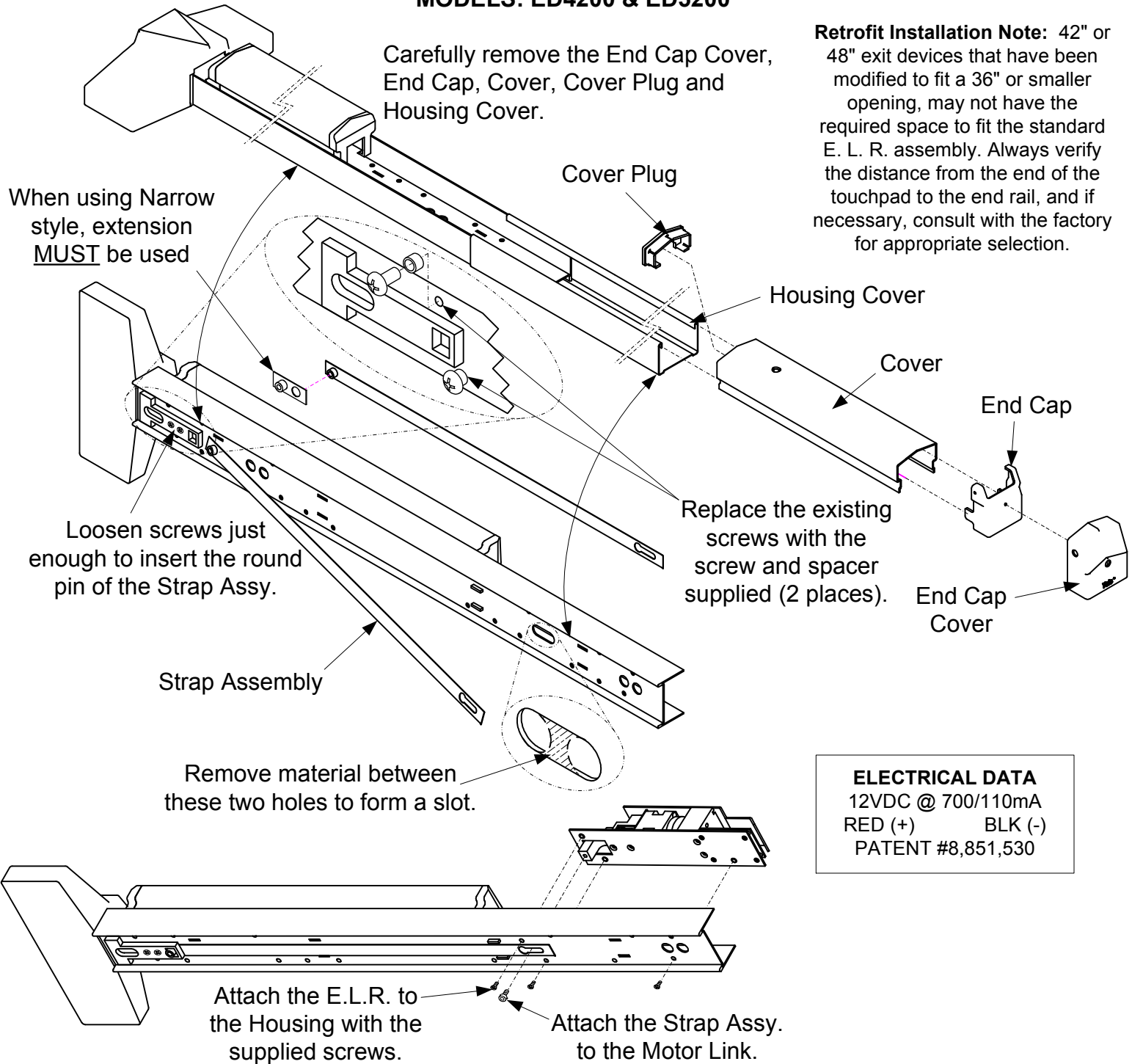

Retrofit Installation Note: 42" or 48" exit devices that have been modified to fit a 36" or smaller opening, may not have the required space to fit the standard E. L. R. assembly. Always verify the distance from the end of the touchpad to the end rail, and if necessary, consult with the factory for appropriate selection.

ELECTRICAL DATA	
12VDC @ 700/110mA	
RED (+)	BLK (-)
PATENT #8,851,530	

Replace Housing Cover, Cover with Plug, End Cap and the End Cap Cover.

Any suggestions or comments to this instruction or product are welcome. Please contact us through our website or email engineer@sdsecurity.com