



INSTALLATION INSTRUCTIONS

WDRB WOOD DOOR REINFORCEMENT BOX

The most important elements for the proper installation of the Hi/Shear magnet assembly are the midpoint of the armature and the midpoint of the magnet must line up exactly. All Centerlines of the armature must line up with the respective centerlines of the magnet.

1565
Lock Dimension: 10-7/16" L x 1-1/2" W x 1-5/8" D
Armature Dimension: 11" L x 1-3/8" W x 7/8" D

1566
Lock Dimension: 10-7/16" L x 1-1/2" x 1-1/16" D
Armature Dimension: 11" L x 1-3/8" W x 7/8" D

Voltage: 12vdc @ 800mA
24vdc @ 400mA

WDRB Dimension: 11" L x 1-1/2" W x 1" D

MIDPOINT IDENTIFICATION
MPM – MIDPOINT MAGNET
MPA – MIDPOINT ARMATURE

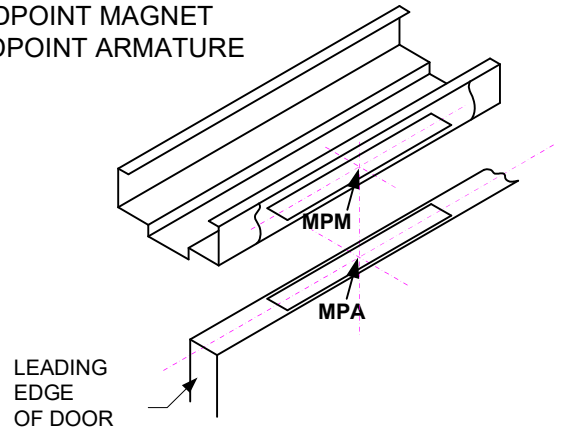

MAGNET LOCK FRAME PREP

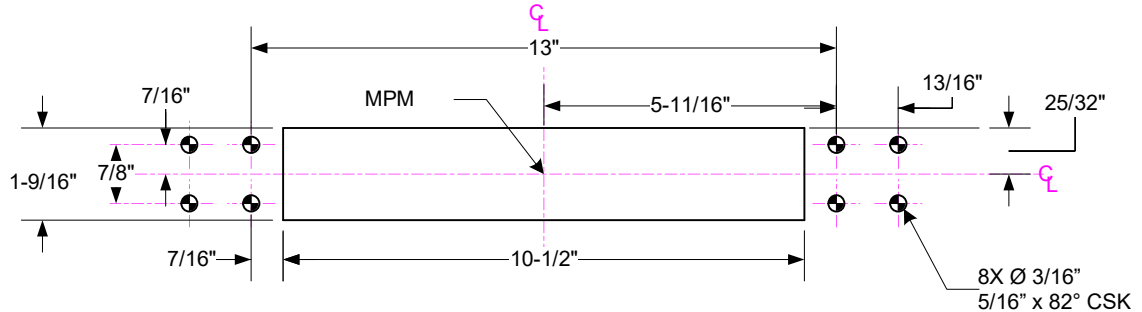

WDRB WOOD DOOR PREP

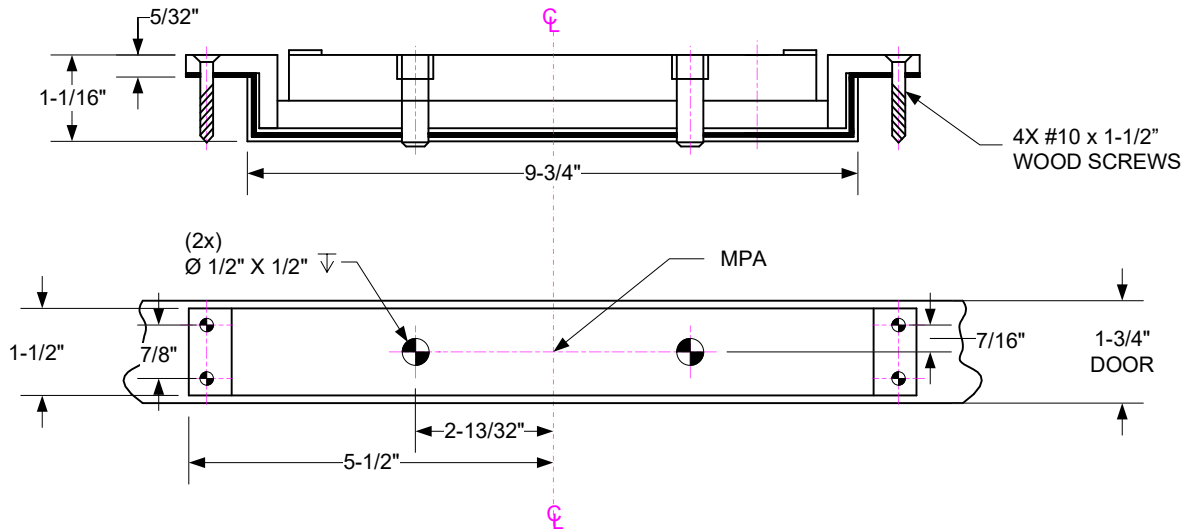

Any suggestions or comments to this instruction or product are welcome. Please contact us through our website or email engineer@sdsecurity.com